

Shanghai, China (Headquarters)
Huizhou, China (Production base)

Shenzhen, China (Sales Center)
Sydney, Australia (Sales Center)

TCSN POWER

Phecda-M L643.2V324A (208kWh)



Huizhou Tianchen Shangneng Technology Co.,Ltd
No. 3 Building,Wuyi village Road,Chenjiang Street,Zhongkai
High-Tech Zone,Huizhou City,Guangdong,China

TCSN Power Technology (Shenzhen) Co., Ltd
1701-2 Qianhai Xiangbin Building,No.18,West Free Trade
Street,Nanshan Street,Qianhai Shenzhen-Hong Kong Cooperation
Zone,Shenzhen

Tel: +86 752-3329629

Email: info@tcsnpower.com



HUIZHOU TIANCHEN SHANGNENG TECHNOLOGY Co., Ltd

1 Introduction

This manual mainly introduces the product introduction, transportation, installation, operation, maintenance,

and troubleshooting of the Phecda-M L643.2V324A(208kWh) .

Before using this product,

please carefully read this manual and operate the energy storage system according to the methods described

in this manual. Otherwise, it may cause equipment damage or personal injury.



Figure 1-1 Schematic diagram of the battery cabinet

Table 1-1 Battery cabinet parameter table

Id	Category	Technical parameters
1	Cell type	3.2V/324Ah, LFP
2	Rated energy of the system	208kWh
3	Battery grouping method	3*1P67S
4	System voltage	502.5~723.6V
5	Chargedischarge rate	≤0.5P
6	Battery efficiency	≥ 94%(excluding AC auxiliary power).
7	Operating temperature range	Discharge:-20~55°C; Charging: 0~55°C
8	Fire fighting methods	Aerosol firefighting
9	Methods of Communication	CAN、RS485、ModbusTCP、LAN
10	Cooling method	Liquid cooling
11	Ingress protection	IP54
12	Corrosion protection level	C3
13	weight	1.515t
14	Size (W*D*H)	2000*1195*1000 mm (without lifting rings).
15	Humidity range	0~95%(no condensation).
16	Maximum working altitude	5000m (>3000m derating)
17	Authentication	GB_T 36276-2023, UN38.3, IEC62619

2 System Configuration

2.1 Battery Park



Figure 2-1 PACK Appearance Diagram

Table 2-1 Battery Box Parameter Table

1	Cell type	LFP
2	Charging rate	≤ 0.5P
3	discharge rate	≤ 1P
4	Composition	1P67S
5	Nominal capacity	324Ah
6	Nominal energy	69.465kWh
7	Nominal voltage	214.4V
8	Operating voltage range	167.5~241.2V
9	Voltage harvesting	Full collection + total positive/total negative
10	Temperature collection	10K /B
11	Maximum operating temperature range	Charging 0°C~55°C; Discharge -30°C~55°C
12	Optimal operating temperature	25°C±2°C;
13	Transport & Storage Temperature (Battery 30% SOC).	-20°C~45°C within one month; -20°C~25°C within 6 months
14	Insulation properties	Resistance ≥ 500MΩ@2500VDC

15	Withstand voltage	Leakage current ≤ 1mA @4500VDC, no spark and no breakdown
16	IP rating	≥ IP67
17	Ambient humidity	< 90% RH (non-condensing)
18	Cooling method	Liquid cooling
19	Product weight	378kg
20	Dimensions (W*D*.H)High).	1192±2mmx1010±2mmx254±2mm

2.2 Battery Rack Specifications

Rated Voltage(V)	643.2	【3modules series】
Series & Parallels	1P201S	
Rated Capacity(Ah)	324	
Voltage range(V)	502.5~723.6	
continuous charge/discharge current(A)	162/324	
Rated Energy(kWh)	180	3modules series, singlecluster
Discharge cut-off voltage(V)	502.5	
Charge voltage(V)	723.6	
Cycle life (@25°C, 0.5C/0.5C,80%DOD)	> 6000	25±2°C, 0.5C/0.5C, 70%SOH
BatteryThermal Management	Liquid cooling	
Operating temperature	-20~55°C	
Operating humidity	5%~95%R.H.	
Communication	CAN/RS485	

2.3 Battery Management System

ESMU Technical Parameters	
Project	Parameters
Central Processing Unit	ARM platform, quad - core, with a maximum main frequency of 2.0GHz
Memory	4GB LPDDR4
Operating System	Linux
SD Card Storage	16GB eMMC 240G - 500G SSD 32G SD card (optional)
Number of Detectable Batteries	Up to 450 cells × 60 clusters
Liquid Crystal Screen	10.1 - inch true - color touch - screen LCD
Data Recording Interval	≥1S (configurable)
Query Methods	On - site panel query, remote access query, data export/download
Alarm Methods	Acoustic - optical alarm, display alarm content, fault output node closure
Communication Interfaces	3 - way LAN, 3 - way isolated CAN, 5 - way isolated RS485, 2 - way USB

DO/DI Interfaces	6 - way DIH IO input with photoelectric isolation 6 - way DIL IO input with electrical isolation 12 - way IO output with relay dry - contact mode 1 - way AC power - failure detection
Remote	Supports MQTT protocol; supports Modbus TCP, IEC61850 protocols
Event Log Database	>100000 event records, including anomaly types, occurrence times, and protection actions, supporting full - life - cycle data storage
ESMU Power Supply	DC24V
ESMU Power Consumption	<10W (initial state with screen on)
Communication Baud Rates	9600bps @ RS485, 250Kbps @ CAN, 100Mbps/1000Mbps @ LAN
Dimensions/Mass	288×190×41.2mm / 1.8kg
Material	Sheet metal
Process	Three - proof paint
Insulation Resistance	500MΩ 1500VDC
Operating Environment	Ambient temperature: -10 - +55°C, relative humidity: <95% (non - condensing), ambient magnetic field: <400A/m, no corrosive or flammable and explosive gases allowed in the surroundings

The energy storage system is equipped with a complete battery management system, adopting a master-slave control architecture, including module level and system level, to achieve comprehensive control, management and protection of the battery system, ensuring the safe and stable operation of the battery system.

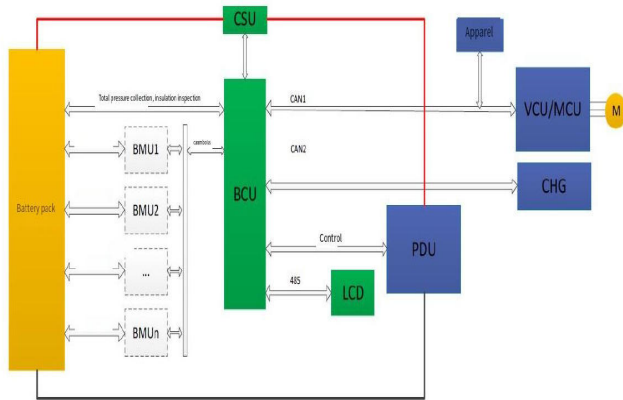

Figure 2-3 Architecture Diagram of BMS

2.4 High voltage box



Table 2-4 Technical parameters of high-pressure box

ID	Name	Technical parameters
1	Current rating	500A
2	Operating voltage	1000V
3	SOC accuracy	5%

2.5 Component Description

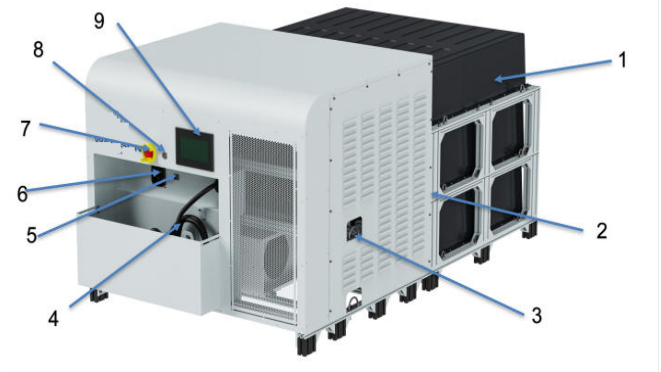

Figure 3-2 Schematic Diagram of Battery Cabinet

NO.	Explain
1	Battery pack*3
2	Bracket
3	Fixed pull tab
4	Charging gun
5	Liquid COM
6	DC-IN
7	Emergency stop button
8	Switch
9	Display

2.6 Thermal management system

The entire thermal management system uses liquid cooling to control the temperature of the battery system. The integrated liquid cooling unit and reasonable pipeline design are used to realize the effective temperature control of the battery cells in the battery system, so that the working environment of the energy storage system is in the best range, and the service life of the whole system is prolonged and the operation is safe and reliable.



Figure 2-6 Schematic diagram of a liquid-cooled unit

Table 2-6 Technical parameters of liquid cooling unit

Id	Technical requirements	Specifications
1	Rated power (refrigeration)	1.42 kW
2	Rated cooling capacity	~3kW
3	Heating power	~2kW
4	Coolant	50% water + 50% ethylene glycol
5	Operating temperature	-30 ~ 55°C
6	High voltage power supply	220VAC±10%
7	Refrigerants	R410a
8	The protection level of the unit's electrical appliances	IP55
9	Dimensions	L800×W940×H1300mm
10	Methods of Communication	RS485/CAN

2.7 Fire protection system

This product divides the energy storage system into multiple levels for protection.

PACK level: early detection and rapid extinguishing of root fire sources;

Cluster level: Focus on controlling external fire sources, preventing their spread, and suppressing their growth.

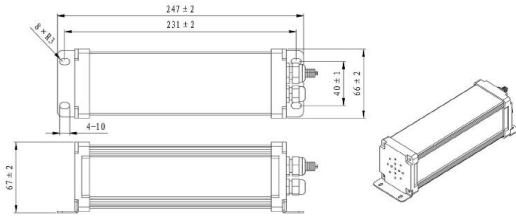

Figure 2-7 Schematic diagram of the fire extinguishing device

Table 2-7 Technical parameters of fire protection system

ID	Project	Performance/Parameters
1	Filling media	aerosol
2	The quality of the filling agent	5*40g(PACK level)+1*300g(cluster level).
3	Supply voltage	24V
4	Methods of Communication	CAN communication/485 communication
5	Protect the space	5m ³
6	expiration date	10 years

3 Precautions

3.1 Safety Precautions

- It must be operated by a professional electrical personnel or a trained technician.
- Make sure the high-voltage power switch is disconnected when installing.
- Please carefully inspect the materials before installation, if there is any missing or damaged, please do not install dangerously.
- Insulating gloves must be worn during installation, and the outside of the metal tool must be tightly wrapped with insulating tape before use.
- During installation, it is strictly forbidden to contact the total positive and total negative of the battery pack at the same time, so as not to hurt people with high voltage.
- Non-professionals are forbidden to disassemble the module shell, let alone touch the internal circuit board, so as not to cause electric shock accidents.
- Without the confirmation of the manufacturer's technical personnel, it is forbidden to modify or use this system on other projects to avoid serious accidents.

3.2 Guidelines for safe use

- Safeguard measures should be provided for the safe and reliable operating environment of the battery system.
- The power should not be greater than the rated power when in use, and the system should be kept away from fire, heat and water sources in use, if the battery leaks or emits peculiar smell, it should be stopped immediately, and the relevant personnel should be notified in time to deal with it.
- The battery system is fully charged and fully discharged every six months, and the recommended charge and discharge rate is 0.5C, and detailed records are made.
- Before the energy storage battery is stored for a long time and operated, the battery system must be inspected for safety to avoid equipment damage or system safety problems caused by loose connections, water vapor condensation, rust or mold.